

## **10x // SLIDING THERMAL INSTALLATION STEPS**

- 1) Collect all necessary items near installation area and be sure that all items are visible.
- 2) Connect upper rail and side posts with corner connection plate as U shape and make the fixation of skeleton at project place.
- 3) Place side plastics of bottom rail and put between the side posts. Before fixation be sure that side posts and bottom rail touch each others and in balance. When you sure, make the fixation of bottom rail through the ground.
- 4) Start to place glass panels as start of outside through the inside as one by one. Be sure that first and last panels should be with lock and at right direction and middle ones will be standard panels.
- 5) After panels assembly completed, make the fixation of winders. Standard arm should be placed inner side and lockable arm should be placed outer area in terms of safety.
- 6) As last make the panel height adjustment through the bottom wheels while turning screw at intended direction. Make sure that two panels connect each other as 90 degree and in balance.
- 7) Apply the silicone fixation to provide water thightness. Silicone should be applied outer area for side posts - upper rail and inner area for bottom rail .

### **LARİBA TEKNOLOJİ YATIRIM A.Ş.**

1

2

3

4

5

6

7

8

# 10x // SLIDING THERMAL INSTALLATION STEPS

1-Collect all necessary items near installation area and be sure that all items are visible.

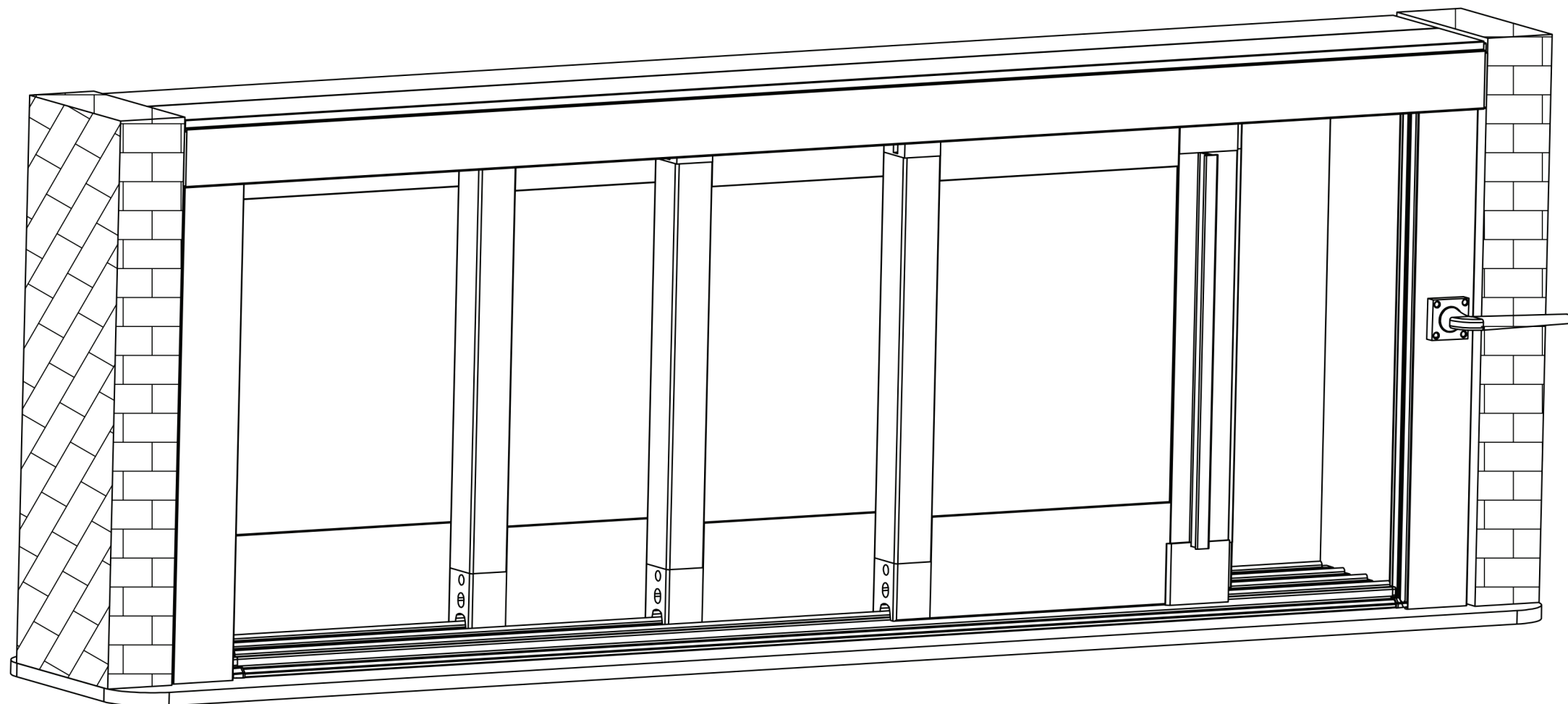
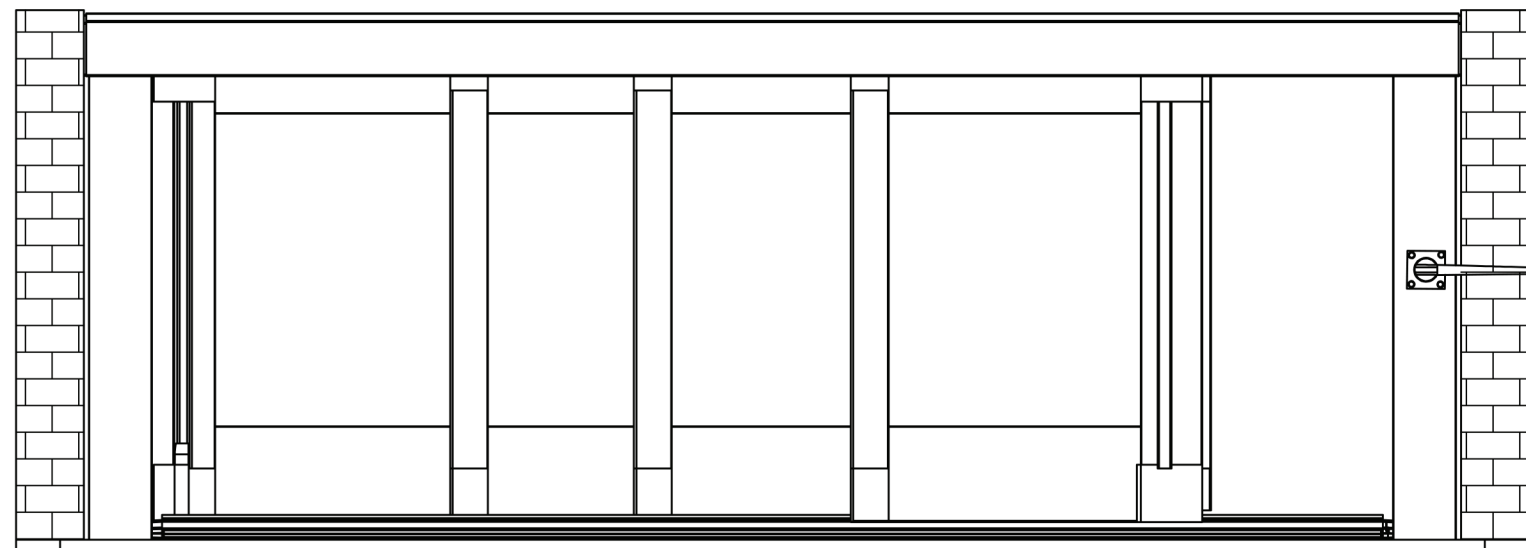

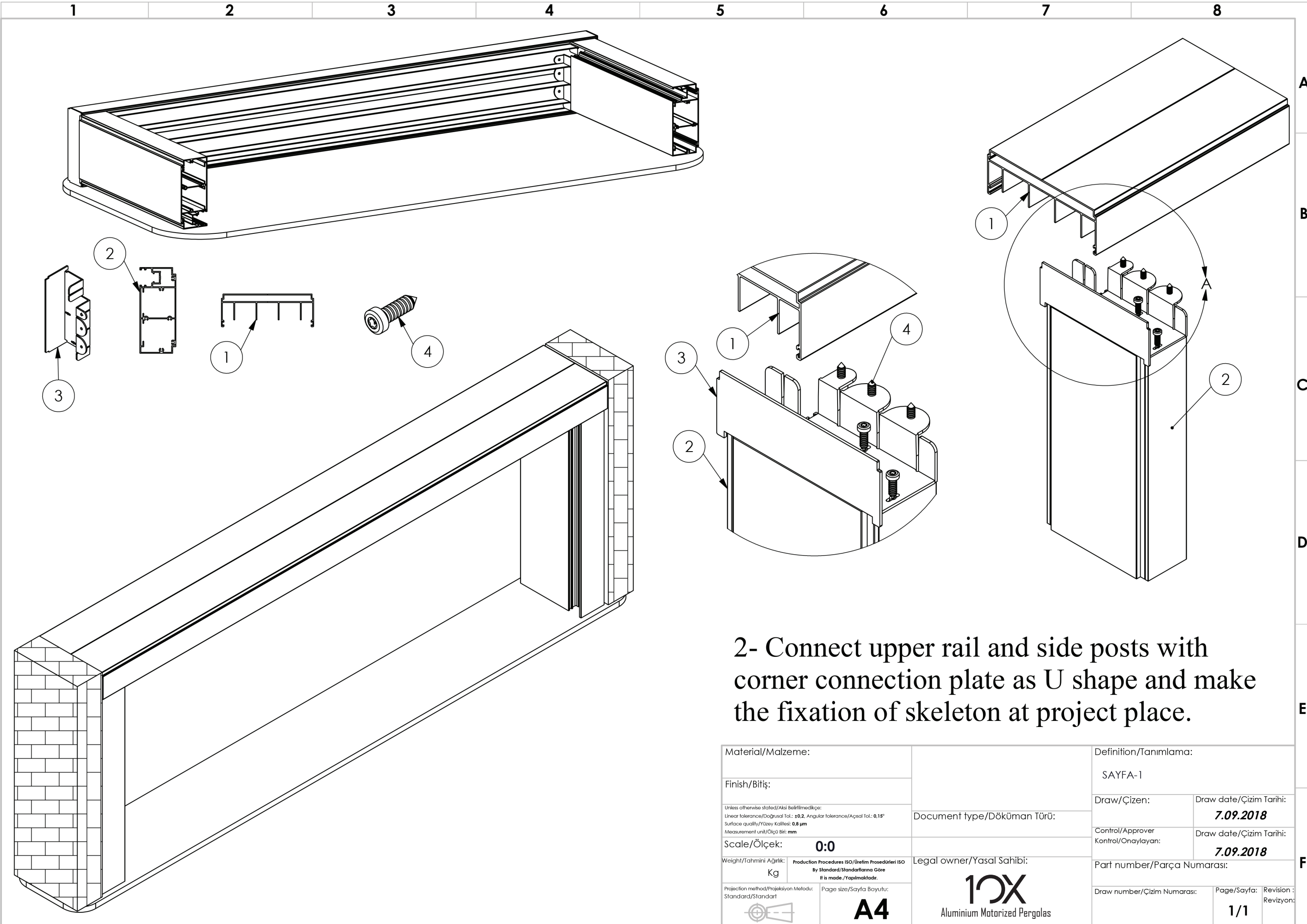

2- Connect upper rail and side posts with corner connection plate as U shape and make the fixation of skeleton at project place.

Material/Malzeme:		Definition/Tanımlama:	
Finish/Bitiş:		SAYFA-1	
<small>Unless otherwise stated/Aksi Belirtilmedikçe:          Linear tolerance/Doğrusal Tol.: ±0.2, Angular tolerance/Açısal Tol.: 0.15°          Surface quality/Yüzey Kalitesi: 0.8 µm          Measurement unit/Ölçü Bir: mm</small>		Draw/Çizen:	Draw date/Çizim Tarihi: <b>7.09.2018</b>
Scale/Ölçek: <b>0:0</b>	Document type/Döküman Türü:	Control/Approver Kontrol/Onaylayan:	Draw date/Çizim Tarihi: <b>7.09.2018</b>
Weight/Tahmini Ağırlık: Kg	Production Procedures ISO/Üretim Prosedürleri ISO By Standard/Standartlaşma Göre It is made./Yapılmaktadır.	Legal owner/Yasal Sahibi:	Part number/Parça Numarası:
Projection method/Projeksiyon Metodu: Standard/Standart	Page size/Sayfa Boyutu: <b>A4</b>		Draw number/Çizim Numarası:
			Page/Sayfa: <b>1/1</b>
			Revision / Revizyon:

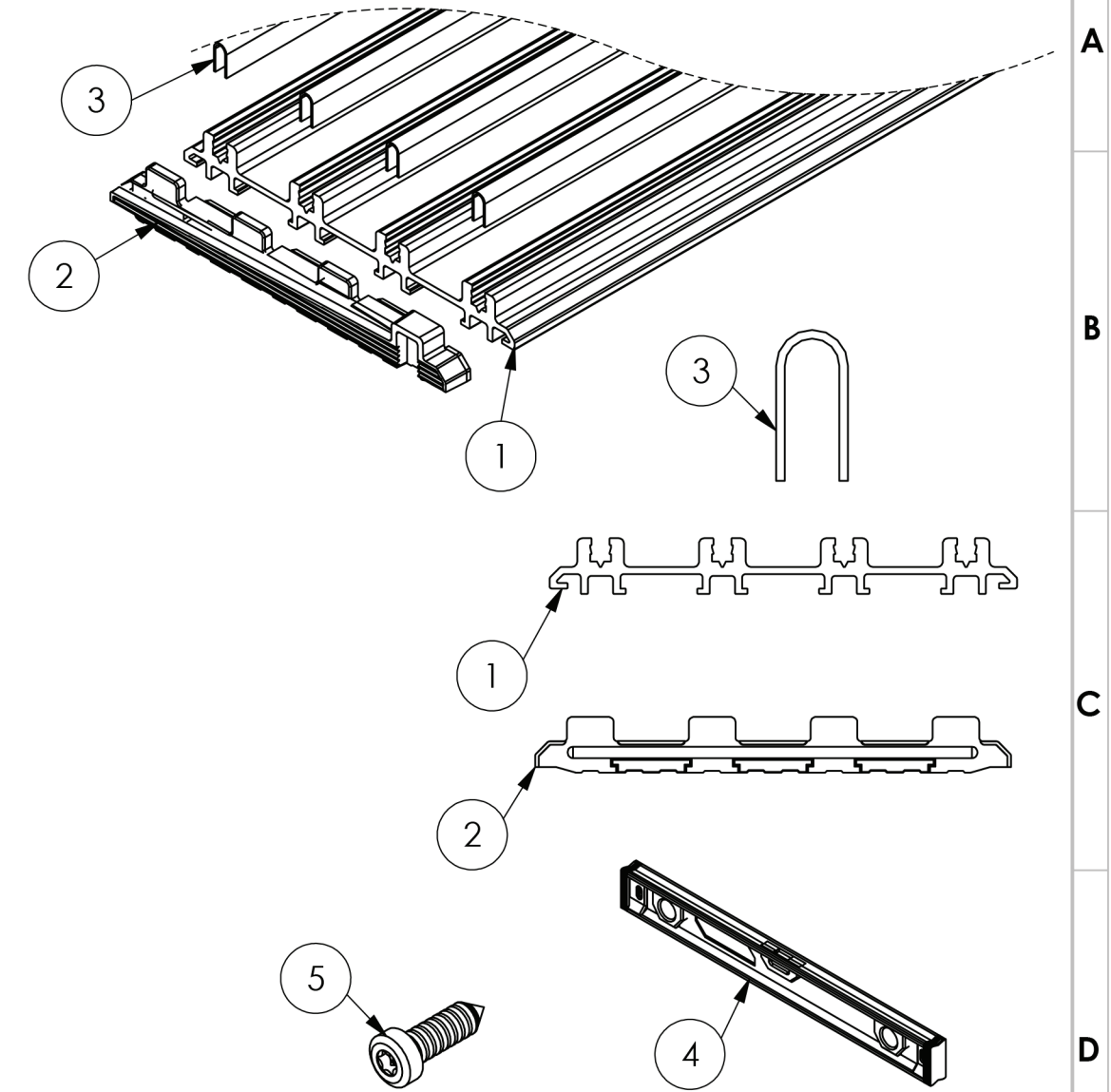
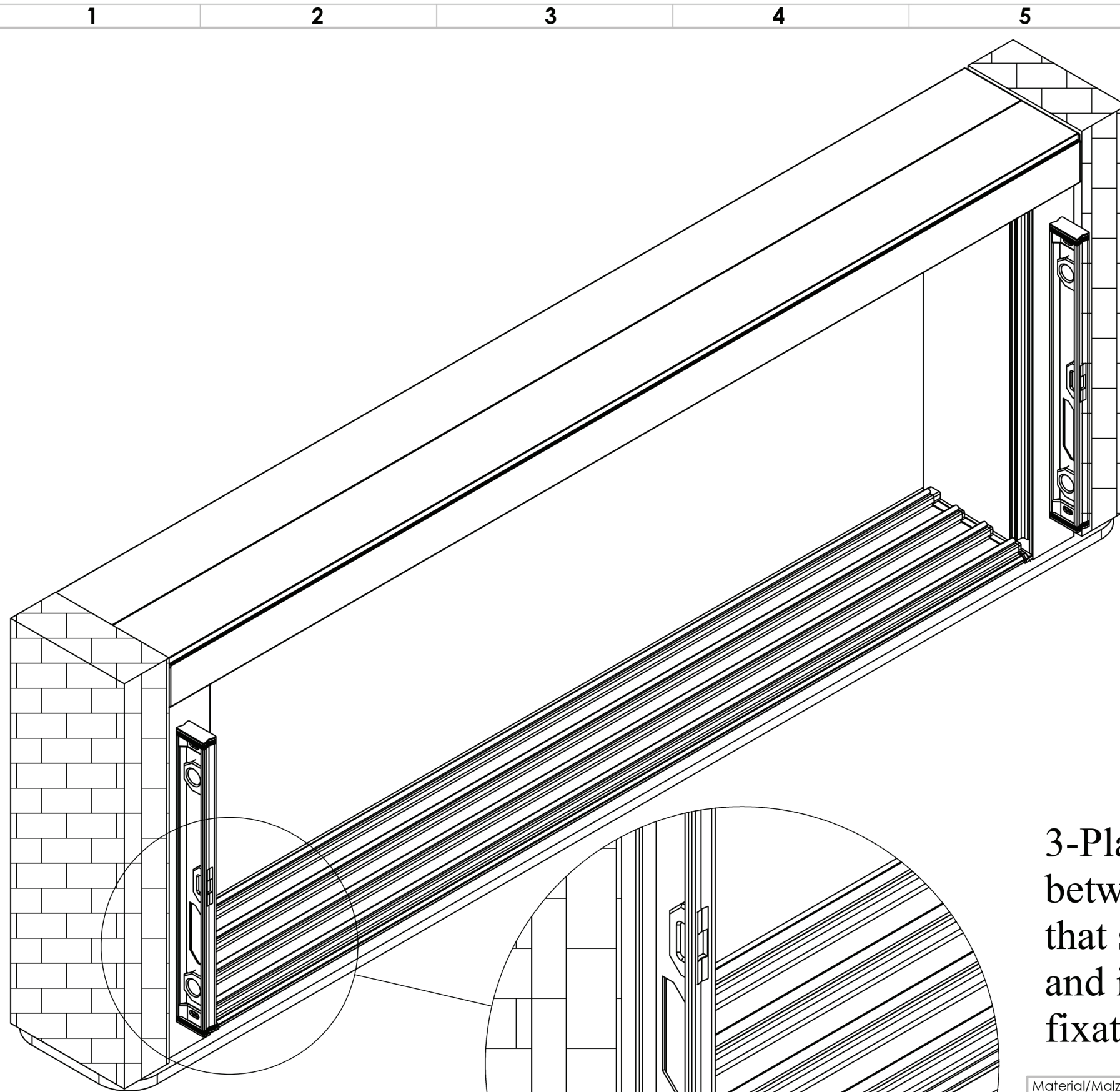

3-Place side plastics of bottom rail and put between the side posts. Before fixation be sure that side posts and bottom rail touch each others and in balance. When you sure, make the fixation of bottom rail through the ground.

Material/Malzeme:		Definition/Tanımlama:	
Finish/Bitiş:		SAYFA-2	
<small>Unless otherwise stated/Aksi Belirtilmedikçe:          Linear tolerance/Dokrusal Tol.: ±0.2, Angular tolerance/Açsal Tol.: 0.15°          Surface quality/Yüzey Kalitesi: 0.8 µm          Measurement unit/Ölçü Bir.: mm</small>		Draw/Çizen:	Draw date/Çizim Tarihi: <b>7.09.2018</b>
Scale/Ölçek: <b>0:0</b>	Document type/Döküman Türü:	Control/Approver Kontrol/Onaylayan:	Draw date/Çizim Tarihi: <b>7.09.2018</b>
Weight/Tahmini Ağırlık: Kg	Production Procedures ISO/Üretim Prosedürleri ISO By Standard/Standartlama Göre It is made./Yapılmaktadır.	Legal owner/Yasal Sahibi:	Part number/Parça Numarası:
Projection method/Projeksiyon Metodu: Standard/Standart	Page size/Sayfa Boyutu: <b>A4</b>		Draw number/Çizim Numarası:
			Page/Sayfa: <b>1/1</b>
			Revision / Revizyon:

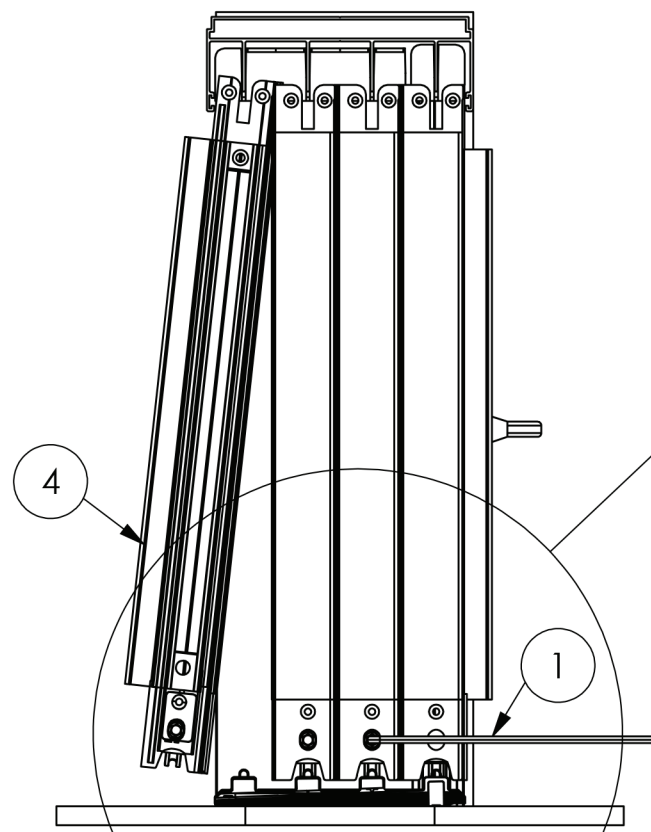
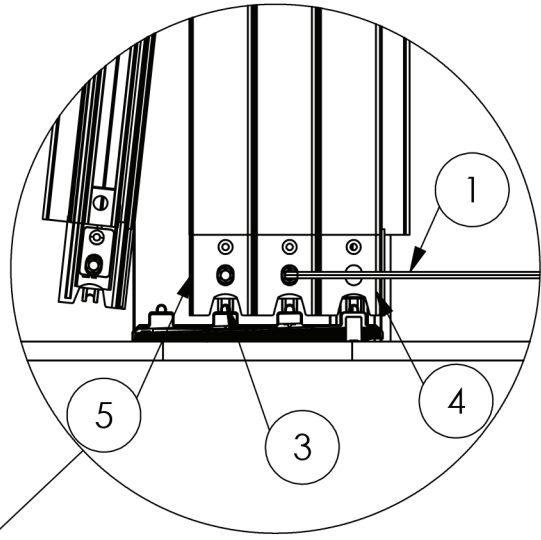
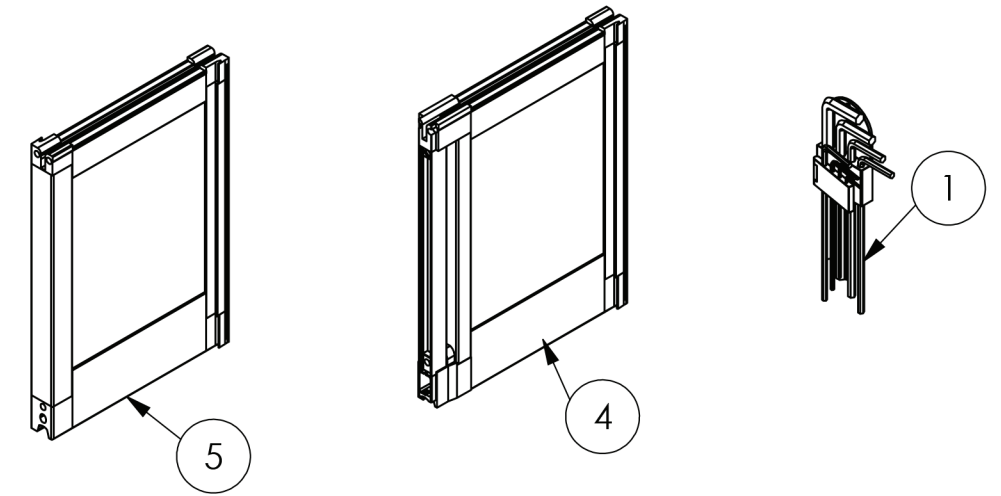
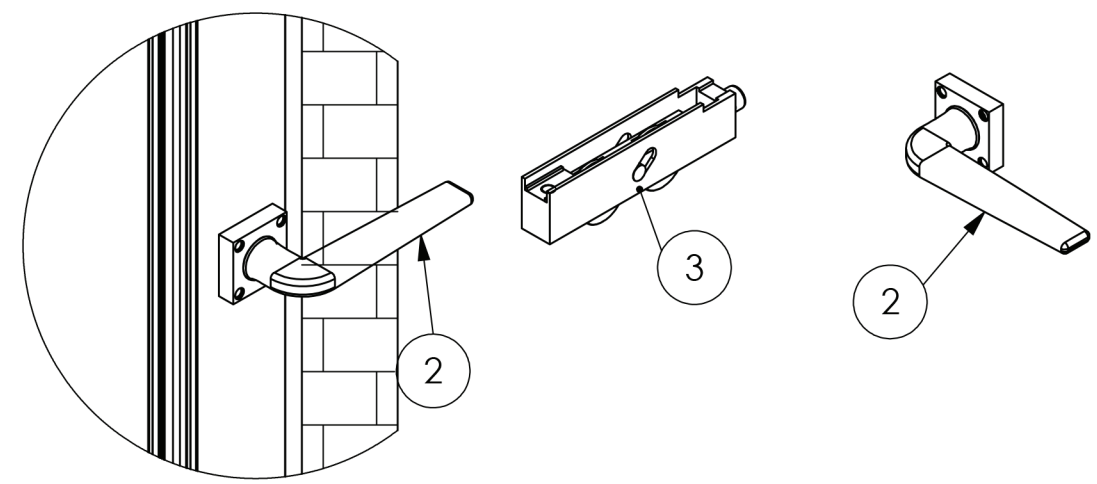
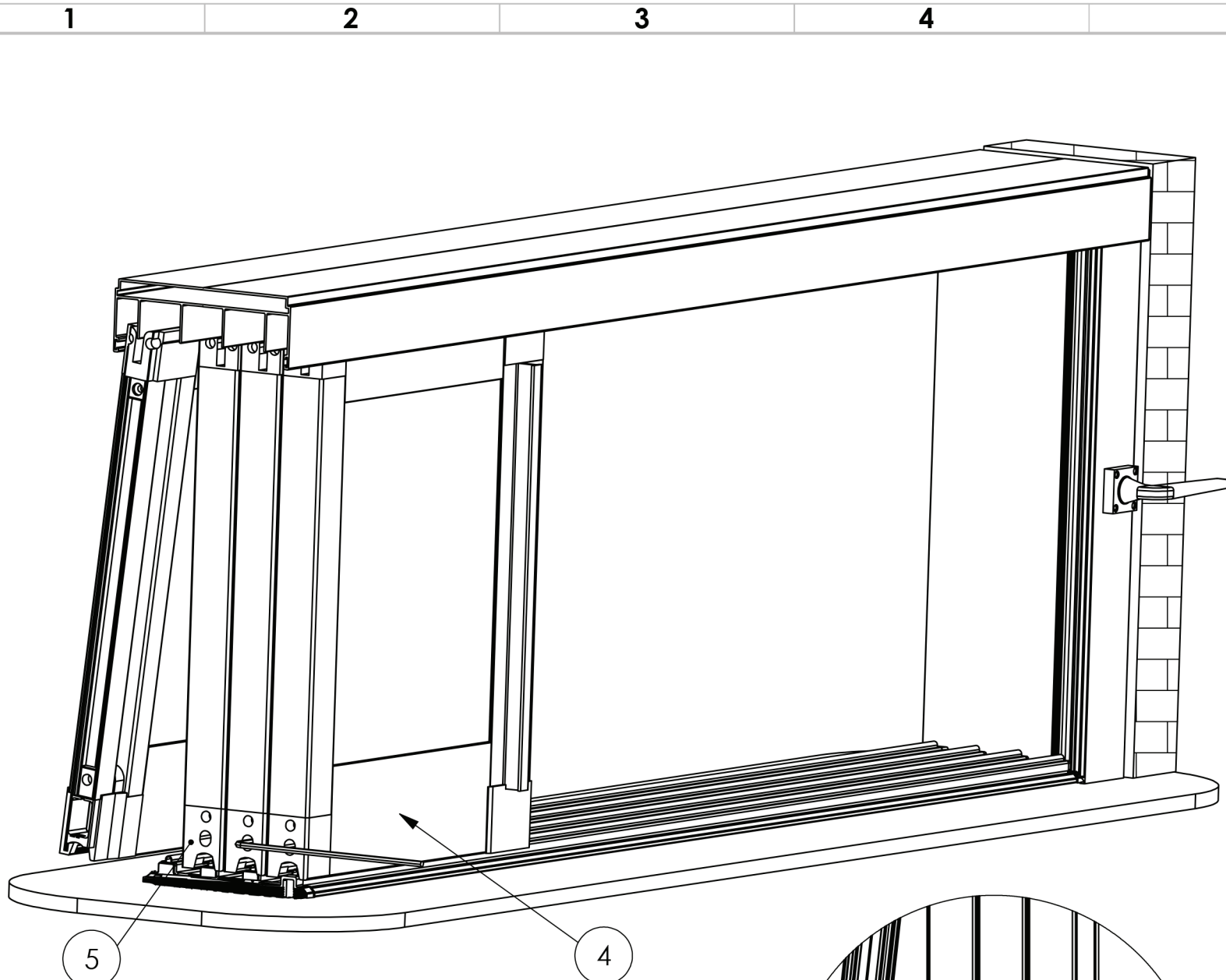

4-Start to place glass panels as start of outside through the inside as one by one. Be sure that first and last panels should be with lock and at right direction and middle ones will be standard panels.

Material/Malzeme:		Definition/Tanımlama:	
Finish/Bitiş:		SAYFA-3	
<small>Unless otherwise stated/Aksi belirtilmedikçe:          Linear tolerance/Doğrusal Tol.: ±0.2, Angular tolerance/Açsal Tol.: 0.15°          Surface quality/Yüzey Kalitesi: 0.8 µm          Measurement unit/Ölçü Bir.: mm</small>		Draw/Çizen:	Draw date/Çizim Tarihi:
Scale/Ölçek: 0:0		Control/Approver Kontrol/Onaylayan:	7.09.2018
Weight/Tahmini Ağırlık: Kg	Production Procedures ISO/Üretim Prosedürleri ISO By Standard/Standartlaşımına Göre It is made./Yapılmaktadır.	Legal owner/Yasal Sahibi:	Draw date/Çizim Tarihi: 7.09.2018
Projection method/Projeksiyon Metodu: Standard/Standart	Page size/Sayfa Boyutu: A4	Part number/Parça Numarası:	
		Draw number/Çizim Numarası:	Page/Sayfa: 1/1
		Revision/Revizyon:	

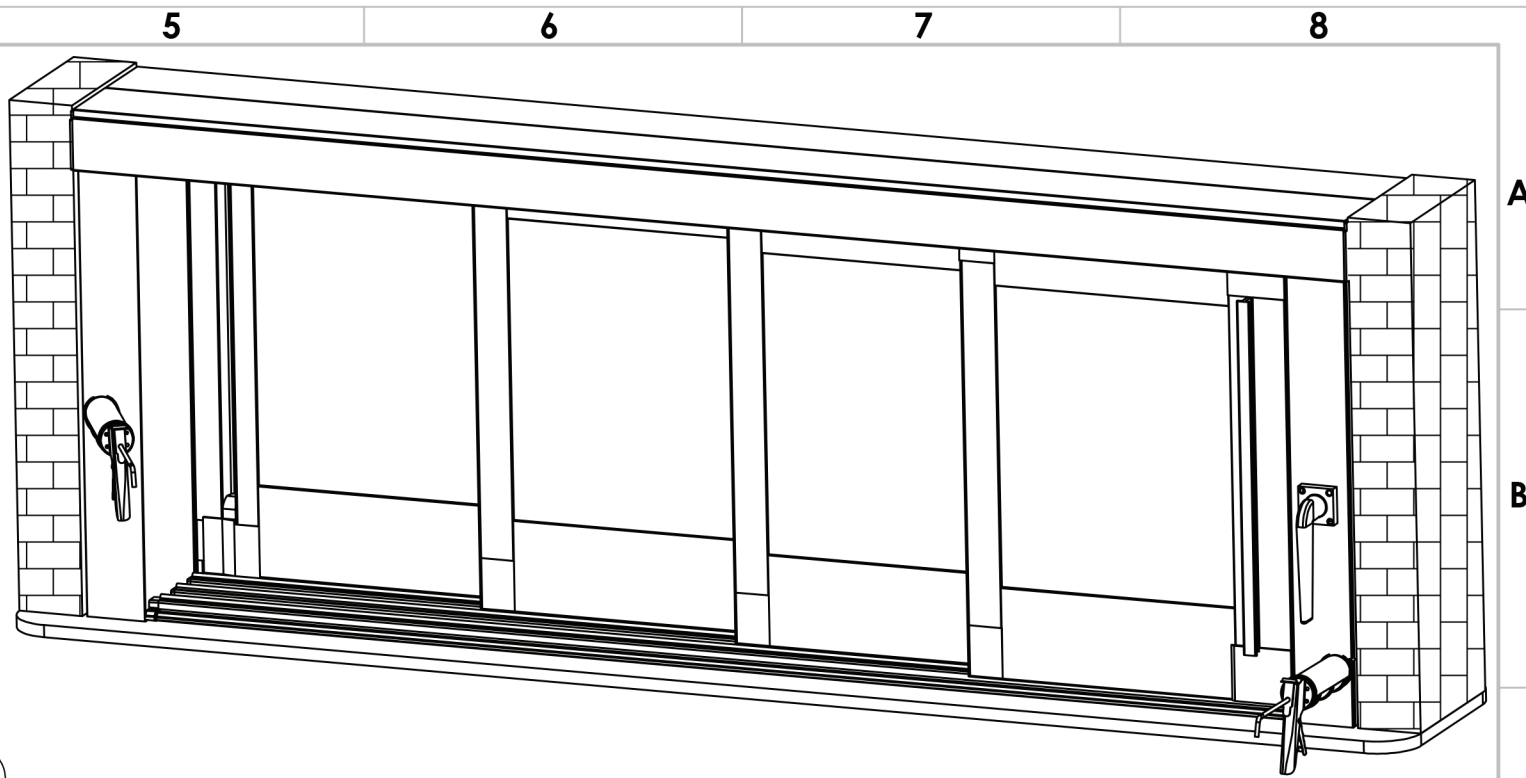
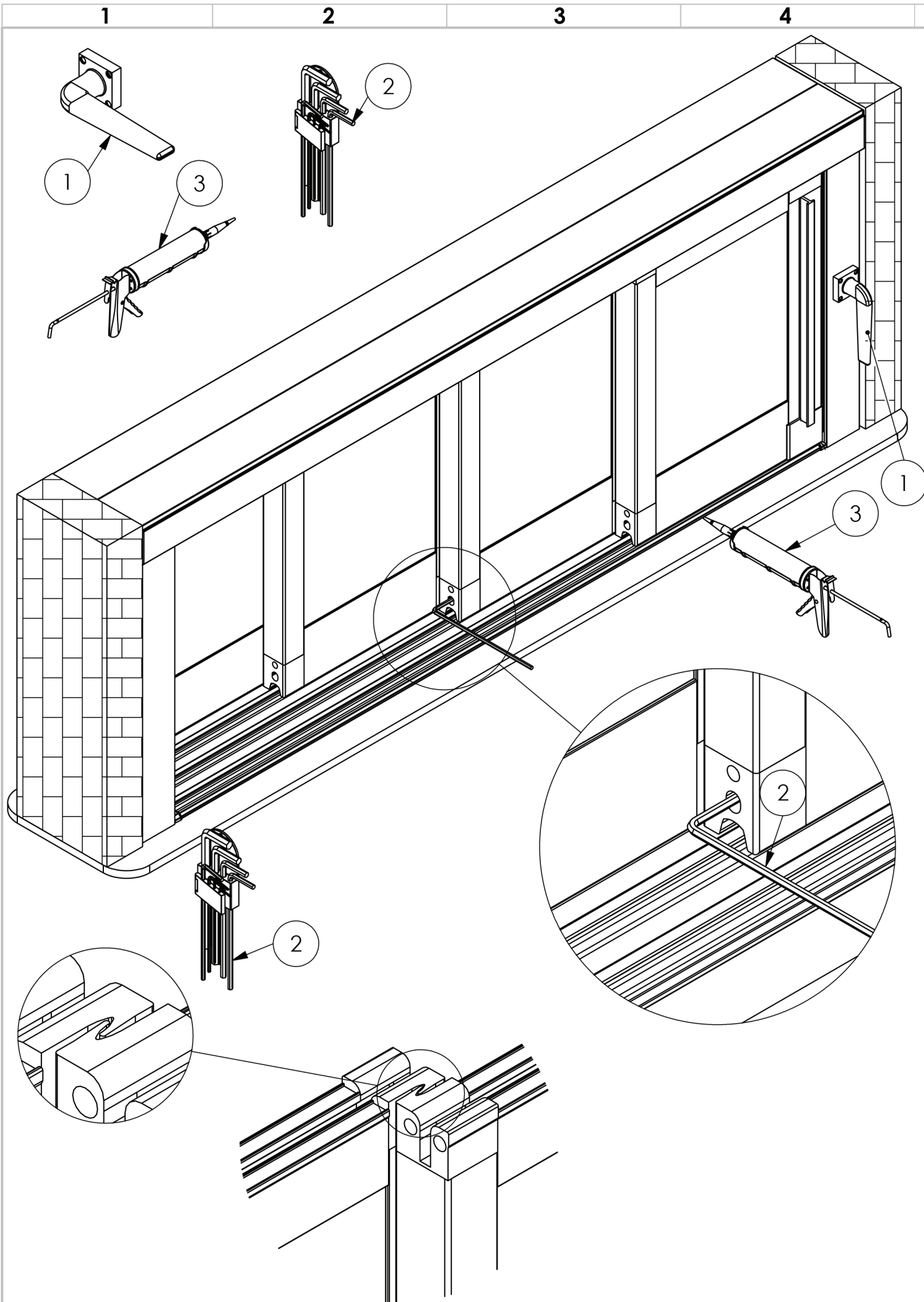

5-After panels assembly completed, make the fixation of winders. Standard arm should be placed inner side and lockable arm should be placed outer area in terms of safety.

6-As last make the panel height adjustment through the bottom wheels while turning screw at intended direction. Make sure that two panels connect each other as 90 degree and in balance.

7-Apply the silicone fixation to provide water thightness. Silicone should be applied outer area for side posts - upper rail and inner area for bottom rail .

Material/Malzeme:		Definition/Tanımlama:	
Finish/Bitiş:		SAYFA-4	
Unless otherwise stated/Aksi Belirtilmedikçe: Linear tolerance/Döğrusal Tol.: ±0.2, Angular tolerance/Ağsal Tol.: 0.15° Surface quality/Yüzey Kalitesi: 0.8 µm Measurement unit/Ölçü Bir.: mm		Draw/Çizen:	Draw date/Çizim Tarihi: <b>7.09.2018</b>
Scale/Ölçek: <b>0:0</b>	Document type/Döküman Türü:	Control/Approver Kontrol/Onaylayan:	Draw date/Çizim Tarihi: <b>7.09.2018</b>
Weight/Tahmini Ağırlık: Kg	Production Procedures ISO/Üretim Prosedürleri ISO By Standard/Standartlaşma Göre It is made./Yapılmaktadır.	Legal owner/Yasal Sahibi:	Part number/Parça Numarası:
Projection method/Projeksiyon Metodu: Standard/Standart	Page size/Sayfa Boyutu: <b>A4</b>		Draw number/Çizim Numarası:
			Page/Sayfa: <b>1/1</b>